

Tensiometer Service, Testing and Calibration¹

A.G. Smajstrla and D.J. Pitts; reviewed by D.Z. Haman²

Tensiometers are useful instruments for measuring soil water status in the field. Tensiometers measure soil water potential or tension, which is a measure of the amount of energy required for a plant to overcome capillary and gravitational forces to extract water from a soil. Thus, tensiometers can be used to schedule irrigations when the soil water tension is low -- that is, before plant water stress occurs. Tensiometers do not measure the osmotic component of soil water potential, which is due to soil salinity. However, this would not be expected to be a limitation to the use of tensiometers in Florida except in saline soils or where saline irrigation water is used.

A tensiometer is a water-filled tube with a vacuum gauge and filling port at the upper end and a ceramic cup at the lower end (Figure 1). When it is placed in the soil, the water in the instrument comes to equilibrium with the water in the soil by flowing through the ceramic cup. At equilibrium, the water tension in the instrument is equal to the water tension in the soil. Then the vacuum gauge measures the soil water tension.

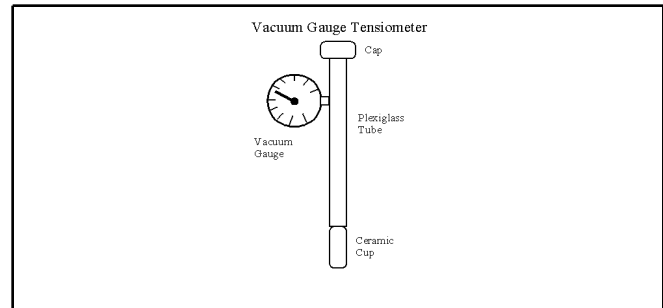

Figure 1.

A tensiometer is used by placing it in the field so that the ceramic cup is located within the root zone of the plants to be irrigated. Then the instrument measures the soil water tension that the plants are experiencing.

The tensiometer is a fairly simple instrument that will work well if it is properly installed and in good condition. The instrument is in good repair if: 1) the vacuum gauge is accurate, 2) the ceramic cup allows free water movement between the soil and the instrument, and 3) there are no air leaks.

New instruments are normally in good repair. However, with time and usage, mechanical vacuum gauges may begin to fail, the ceramic cups may begin to plug, or air leaks may develop. Therefore,

1. This document is BUL319, one of a series of the Agricultural and Biological Engineering Department, Florida Cooperative Extension Service, Institute of Food and Agricultural Sciences, University of Florida. Original publication date April 1997. Reviewed December 2005. Visit the EDIS Web Site at <http://edis.ifas.ufl.edu>.
2. A.G. Smajstrla (deceased), Former Professor, and Dorota Z. Haman, Associate Professor, Agricultural and Biological Engineering Department, Gainesville; D.J. Pitts, Assistant Professor, SW Florida Research and Education Center, Immokalee, Cooperative Extension Service, Institute of Food and Agricultural Sciences, University of Florida, Gainesville FL 32611.

The Institute of Food and Agricultural Sciences (IFAS) is an Equal Opportunity Institution authorized to provide research, educational information and other services only to individuals and institutions that function with non-discrimination with respect to race, creed, color, religion, age, disability, sex, sexual orientation, marital status, national origin, political opinions or affiliations. U.S. Department of Agriculture, Cooperative Extension Service, University of Florida, IFAS, Florida A. & M. University Cooperative Extension Program, and Boards of County Commissioners Cooperating. Larry Arrington, Dean

tensiometers should be periodically tested to insure that they are working properly, and that soil tensions are accurately read. As a minimum, tensiometers should be tested before each crop season for short-season crops. They should be tested at least every three or four months for longer-season or perennial crops. They should also be tested whenever their readings appear to be unusual, such as if the gauge remains on zero even though the soil dries as a crop uses water.

This publication presents procedures for servicing, testing, and calibration of tensiometers so that the user can determine that the instrument is working properly and reading accurately for irrigation scheduling purposes.

SERVICING A TENSIO METER

Servicing a tensiometer means preparing it for field operation or testing. This requires cleaning it if necessary, then filling it with fluid and expelling any entrapped air.

First wash the instrument to remove dirt, algae, bacterial slime and other foreign debris from both the inside and outside of the ceramic cup and tensiometer tube. This can be done with plain water and a brush. Use a small diameter bottle brush to clean inside the tube and cup. Use a household detergent if necessary to clean the instrument thoroughly.

If the instrument, especially the ceramic cup, is slimy this is probably the result of bacterial growth in the soil and water. Wash the ceramic cup and tube in a chlorine solution, using about 1/4 cup of household bleach (5.25% sodium hypochlorite solution) in a gallon of water. You may want to allow the ceramic cup to soak in this solution overnight to be sure that all the bacteria are killed. Then rinse the instrument with water.

Fill the instrument with clean water or water with a mild biocide to help prevent organic growths in the tensiometer fluid. Most tensiometer manufacturers sell a fluid additive that is both a biocide and coloring agent that allows the tensiometer fluid to be easily seen. Deionized water may be used in order to keep the instruments clean longer in the field. However, with time they will again become

contaminated by contact with the soil solution and bacteria in the soil. It is not mandatory that fluid additives be used, however additives will reduce the maintenance needed to keep the instruments clean and working properly.

Allow the ceramic cups to soak in water or tensiometer fluid for several hours or overnight to be sure that the ceramic is thoroughly saturated. Then fill the instrument with tensiometer fluid. A plastic squeeze bottle is useful for filling the instruments.

Remove excess air from the instrument using a hand held vacuum test pump available from the tensiometer manufacturer (Figure 2). The vacuum test pump has a neoprene suction cup or stopper that allows it to replace the tensiometer cap. Then as the pump is operated, air is extracted from the ceramic cup, tube, and vacuum gauge and pulled to the top of the tube. Pump the tensiometer several times, refilling the tube with fluid each time if necessary until no further air is removed. Then remove the vacuum pump and refill the tube to the top with tensiometer fluid. The instrument is now ready to be tested for leaks or capped for use.

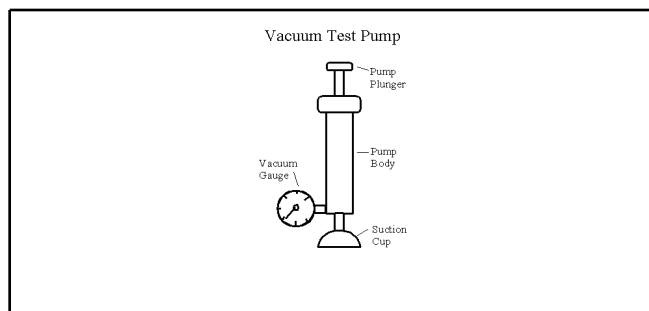

Figure 2.

TESTING A TENSIO METER

To determine whether a tensiometer is working properly, three tests need to be conducted: 1) test for air leaks, 2) test that the mechanical vacuum gauge works, and 3) test that water can flow through the ceramic cup.

Begin by testing for large air leaks using the hand-held vacuum test pump. After the tensiometer has been cleaned and serviced as previously described, fill it completely full of fluid, then use the vacuum pump to make this test. Operate the vacuum pump to create a vacuum in the instrument and look

for the continued flow of air into the instrument. A steady stream of air bubbles will indicate a large air leak.

When large air leaks occur, they are often around fittings or gaskets such as where the pressure gauge is threaded into the plexiglass tube or where an o-ring seal is used to attach the tip to the tube on some tensiometer models. If so, these can often be repaired by using thread sealant or replacing o-rings. Large air leaks sometimes occur where the ceramic cup is cemented onto the plexiglass tube. If that is the case, it can often be repaired with a waterproof epoxy, however, all components need to be thoroughly dry before applying epoxy. Several days may be required to thoroughly dry the ceramic cup and the epoxy.

If no large air leaks occur, the mechanical vacuum gauge can be tested by comparing its reading with the test gauge on the vacuum test pump. Always buy a test pump with a test gauge installed. Then when the vacuum pump is used, the tensiometer gauge should read the same values as the test gauge. This is a quick and easy test that the tensiometer vacuum gauge is working and that its readings are approximately correct. Unfortunately, if the instrument gauge does not work, or if it is not accurate, most types must be replaced. Some can be calibrated, however, most that are commonly used must be discarded and replaced with a new gauge.

The final instrument test is a test for leaks and proper operation of the ceramic cup with the tensiometer sealed and ready for field installation. After the extraction of air and test of the vacuum gauge as described above, refill the tensiometer to the top and seal it with the tensiometer cap. Then place or hang the instrument in the atmosphere where water can evaporate from the ceramic cup to simulate soil drying. Because the instrument is sealed, as evaporation occurs the vacuum gauge reading should slowly increase (depending on the rate of drying) throughout the tensiometer range. This process may take an hour or more during which time the tensiometer fluid can be observed for streams of small air bubbles which indicate small leaks in the instrument. Such leaks must be found and repaired because if they are not, the instrument will require frequent refilling in the field and the gauge reading will lag the true soil reading.

While the above slow-leak test is being conducted, a test of the ceramic cup flow properties is being conducted at the same time. If the ceramic cup pores are plugged, water will not flow through the ceramic and the instrument will not respond or will respond only very slowly to drying by the atmosphere. This will indicate a need for the ceramic to be cleaned more thoroughly before the instrument will work in the field. Because of the small pore sizes in the ceramic, they can readily be plugged by oil, grease, or other contaminants. Never use oil or grease on or around these instruments where the ceramics might become contaminated.

TENSIOMETER CALIBRATION

Because tensiometers commonly use mechanical vacuum gauges, these instruments can become inaccurate or fail with time. Calibration is periodically required when tensiometers are used to control irrigation scheduling, especially for crops that are very sensitive to water stress. Two calibrations can be performed: 1) the vacuum test gauge quick calibration, and 2) the vacuum chamber detailed calibration.

Vacuum Test Gauge Quick Calibration

The vacuum test gauge calibration was previously described in the tensiometer testing section of this publication. This is a quick test made by comparing the tensiometer gauge with the vacuum test gauge. The accuracy of this calibration depends on maintaining and using an accurate test gauge. If the tensiometer vacuum test pump used is equipped with a check valve to sustain the vacuum in the tensiometer tube, and a small bleed valve to slowly release the vacuum as desired, then the test instrument can easily be used to compare the gauges at several vacuum levels. First, operate the test pump to create a high level of vacuum in the tensiometer and read both gauges when they have equilibrated. Then operate the bleed valve to gradually reduce the vacuum level, stopping at each new level to read and record both vacuum gauges.

This procedure allows a quick test of a tensiometer gauge to be made throughout its range of operation. It offers the advantage that an instrument's calibration can quickly be checked in the field, using

only a small, easily-portable vacuum pump and test gauge.

Vacuum Chamber Detailed Calibration

Figure 3 shows a vacuum chamber that can be constructed to allow detailed tensiometer calibrations and extended leak tests to be performed. The calibration chamber is constructed from pressure-rated PVC pipe and PVC end caps. Holes are drilled along the length of the pipe for tensiometer ports, and other small ports are drilled for the installation of a vacuum regulator, vacuum gauge, and drain valve. Number 11 neoprene rubber stoppers with 3/4 or 7/8-inch diameter holes in them are used to seal tensiometers into the chamber, and solid stoppers are used to plug tensiometer access ports when they are not in use. A wooden stand is used as a base for the chamber.

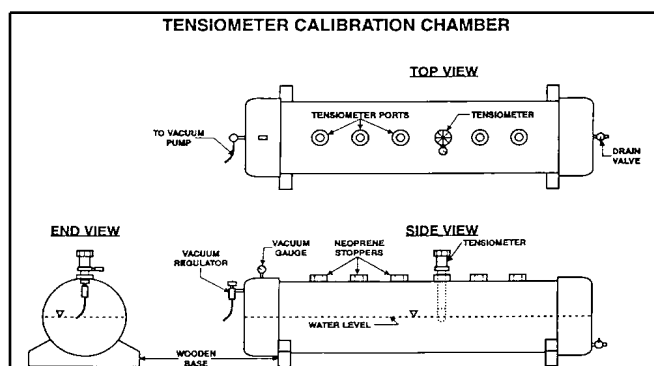

Figure 3.

A vacuum pump is used to create the vacuum required in the chamber, and a vacuum regulator is used to precisely set the vacuum level during calibration. Water is placed in the chamber to a level approximately midway up the ceramic cup.

Tensiometers are calibrated by servicing them and installing them in the chamber as shown in Figure 3. A vacuum level is created by operating the vacuum pump and setting the vacuum regulator, then the tensiometer gauges are allowed to come to equilibrium with the vacuum level set, and both the chamber vacuum gauge and the tensiometer gauges are read. This process is repeated at several vacuum levels to verify that each instrument is accurate or to create a calibration curve for each instrument tested.

The advantage of this method is that the entire instrument is inserted into the chamber during the test procedure. Thus, leak tests, ceramic cup flow properties, and tensiometer vacuum gauges are all tested at the same time. The vacuum level can be maintained for a long time (such as overnight) to test for slow leaks.

Both manually-read tensiometers and automatic switching tensiometers or pressure transducers can be calibrated using the chamber described here. Since all of these instruments measure soil water tension, all of the calibrations performed are independent of soil type, thus no further field calibration is required. When manual or pressure-transducer tensiometers are used, calibration curves can be determined by measuring the chamber vacuum level and the gauge or transducer outputs at the same time. A mercury manometer or high precision test gauge can be used to accurately monitor the chamber vacuum level if that degree of accuracy is required.

Automatic switching tensiometers use a magnetic pickup switch to indicate when a preset vacuum level has been reached. At that point, an irrigation can be automatically scheduled. To calibrate these switching tensiometers, the desired vacuum level is set in the chamber and the tensiometer vacuum gauges are allowed to equilibrate with it. Then the magnetic pickup switch is slowly rotated until switch closure occurs. This setting is marked on the vacuum gauge. This procedure insures that the switch setting will occur at the same vacuum level in the field. Again, no field calibration of these instruments is required. All calibration can be done in the convenience and comfort of the shop or laboratory.

SUMMARY

Tensiometers are useful instruments for irrigation scheduling under field conditions, however, they require servicing, testing and calibration to insure that they are working properly. A tensiometer is a fairly simple instrument that will work well if it is properly installed and in good repair. The instrument is in good repair if: 1) the vacuum gauge is accurate, 2) the ceramic cup allows free water movement between the soil and the instrument, and 3) there are no air leaks. This publication presents both field and

laboratory procedures for servicing, testing, and calibration of tensiometers so that the user can determine that the instrument is working properly and reading accurately for irrigation scheduling purposes.

Because tensiometers commonly use mechanical vacuum gauges, these instruments can become inaccurate or fail with time. Calibration is periodically required if these instruments will be used to control irrigation scheduling, especially for crops that are very sensitive to water stress. Two calibrations can be performed: 1) the vacuum test gauge calibration, and 2) the vacuum chamber calibration. The vacuum test gauge procedure allows a quick test of a tensiometer gauge to be made throughout its range of operation. It offers the advantage that an instrument's calibration can quickly be checked in the field, using only a small, easily-portable vacuum pump and test gauge.

With the vacuum chamber method, the entire instrument is inserted into the chamber during the test procedure. Thus, leak tests, ceramic cup flow properties, and tensiometer vacuum gauges are all tested at the same time. The vacuum level can be maintained for a long time (such as overnight) to test for slow leaks.

All of the calibrations performed are independent of soil type, thus no field calibration is required. All calibrations can be done in the convenience and comfort of the shop or laboratory.

REFERENCES

Pitts, D.J., T.A. Obreza, D. Parker and A.G. Smajstrla. 1996. A vacuum chamber for testing tensiometers. Technical paper presented at the Florida Section ASAE annual meeting, May, 1996. Cocoa Beach, FL.

Smajstrla, A.G., D.S. Harrison and F.X. Duran. 1984. Tensiometers for soil moisture measurement and irrigation scheduling. Ext. Circ. 487. Fla. Coop. Ext. Svc., Univ. Of Fla., Gainesville.