

# Gray Water Reuse in Florida<sup>1</sup>

Christopher J. Martinez<sup>2</sup>

Reusing gray water from showers, bath tubs, clothes washing, and some sinks for flushing toilets and urinals and irrigating non-edible portions of the landscape is a way to reduce the need for new sources of fresh water and reduce reliance on groundwater resources. The purpose of this document is to provide an overview of the recycling of gray water, the ways that gray water can potentially be used, and the regulations and guidelines for gray water reuse in Florida. This document will conclude with a discussion of some of the potential barriers to gray water reuse in Florida and elsewhere.

## What is Gray Water?

Graywater, greywater, gray water, or grey water are all terms that have the same meaning. In this document we use the word gray water since this is what is used in both the International Plumbing Code and the Florida Building Code (ICC 2009; Florida Building Codes 2007). The exact definition of gray water varies from state to state, but generally includes any household wastewater other than that which comes in direct contact with human waste (such as water used for toilet flushing) or that has the potential to contain a large amount of organic material (such as food waste from kitchen sinks). As defined in Chapter 381 of the Florida Statutes, gray water includes water from baths, showers, clothes washers, laundry trays, and sinks, but does not include wastewater from kitchen sinks (Florida Statutes 2008). Wastewater from toilets, urinals, and kitchen drains is classified as blackwater and must be directly connected to a public sewer or to an onsite sewage and treatment disposal (e.g. septic) system (Florida Building Codes 2007).

Wastewater from kitchen drains is classified as blackwater due to higher organic contents (food waste) which can lead to greater microbial activity, and thus is of greater concern to public health. In some states laundry water may be considered as blackwater when used for washing materials soiled by human waste, such as diapers.

## Why Reuse Gray Water?

Reusing gray water reduces the use of drinking-quality (potable) water for non-drinking quality (non-potable) needs. Potable water is often used unnecessarily around the household for purposes for which gray water would be acceptable. The average indoor water use in the US is 69.3 gallons per person per day (Mayer et al. 1999) and approximately 50–60% of this is used in showers, bathtubs, sinks, and as laundry water, while toilet flushing uses approximately 25% (Figure 1). Gray water is of lesser quality than tap water but is generally of higher quality than blackwater. Replacing some or all of the potable water used for non-potable needs (such as toilet flushing and irrigation of non-edible portions of the landscape) can significantly reduce demand for fresh water. Reducing demands on fresh water can reduce the need for new (and potentially costly) municipal sources of fresh water, reduce depletion of groundwater and associated environmental impacts, and reduce the volume of household wastewater sent to septic tanks or treatment plants.

While reusing gray water is a method of conserving fresh water, it can be a potential public health issue if not used appropriately. Gray water can contain bacteria and human

1. This document is AE453, one of a series of the Agricultural and Biological Engineering Department, UF/IFAS Extension. Original publication date January 2010. Reviewed March 2016. Visit the EDIS website at <http://edis.ifas.ufl.edu>.

2. Christopher J. Martinez, associate professor, Department of Agricultural and Biological Engineering; UF/IFAS Extension, Gainesville, FL 32611.

The Institute of Food and Agricultural Sciences (IFAS) is an Equal Opportunity Institution authorized to provide research, educational information and other services only to individuals and institutions that function with non-discrimination with respect to race, creed, color, religion, age, disability, sex, sexual orientation, marital status, national origin, political opinions or affiliations. For more information on obtaining other UF/IFAS Extension publications, contact your county's UF/IFAS Extension office.

U.S. Department of Agriculture, UF/IFAS Extension Service, University of Florida, IFAS, Florida A & M University Cooperative Extension Program, and Boards of County Commissioners Cooperating. Nick T. Place, dean for UF/IFAS Extension

pathogens. For this reason each permitted use has its own treatment and disinfection requirements.

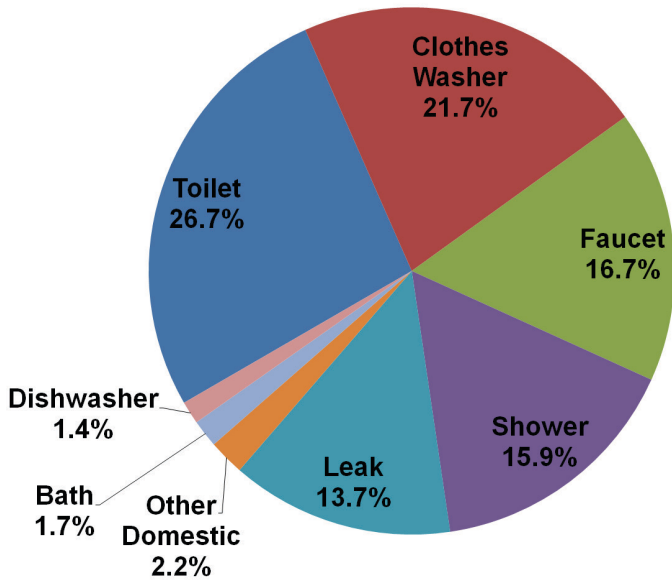

Figure 1. Average Indoor Water Use for 12 North American Cities. (Source: Mayer et al. 1999, Residential End Uses of Water)

## How Can Gray Water be Used?

Just as the definition of gray water varies from state to state, so do the permitted uses of gray water. States in more arid regions (such as Arizona, California, New Mexico, and Texas) that have experienced more acute pressures on water supplies tend to have the most comprehensive regulations and guidelines for gray water reuse. A number of states allow gray water systems to be installed on a case-by-case basis, but may not define specific guidelines or legal parameters for approval. Many states simply adopt Appendix C of the International Plumbing Code (ICC 2009), which lists toilet flushing and landscape irrigation as acceptable permitted uses of gray water.

Prior to March 1, 2009 the Florida Building Code adopted, in entirety, the International Plumbing Code recommended uses and gray water was approved for use for flushing of water closets (conventional flush toilets) and urinals and for subsurface landscape irrigation (Florida Building Code 2007). After March 1, 2009, the Florida Building Code was updated and specifies that gray water may only be used for flushing of toilets and urinals (Florida Building Code 2009) and any discharge from the building must be connected to a public sewer or an onsite sewage treatment and disposal system in accordance with Chapter 64E-6, Florida Administrative Code (Florida Department of Health 2006). Landscape irrigation is no longer included as a permitted use of gray water in the Florida Building Code. Contact the local Health Department about installing a gray water system.

## Permitted Uses and Requirements for Gray Water Reuse in Florida

There are several requirements for gray water systems for flushing toilets (water closets) and urinals in Florida. Distribution piping must be clearly identified as containing non-potable water by pipe color or with metal tags. Gray water must be filtered, disinfected, and dyed. Gray water storage reservoirs must be appropriately sized and must have a make-up potable water supply. Storage reservoirs must also have drains and overflow pipes which must be indirectly connected to the sanitary drainage system. Figure 2 shows the four main components of a gray water system for flushing toilets and urinals:

- Filter system
- Storage reservoir
- Disinfection unit
- Coloring dye injection unit

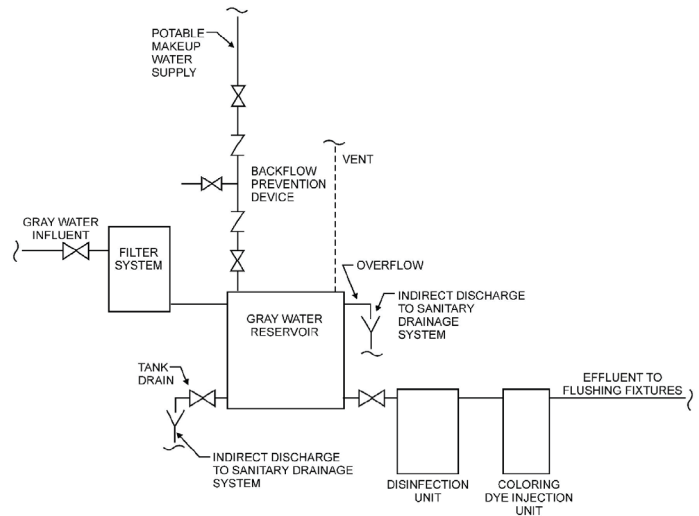

Figure 2. Gray water system for flushing conventional toilets and urinals.

Credits: 2009 International Plumbing Code, Copyright 2009. Washington DC: International Code Council. Reproduced with permission. All rights reserved. [www.iccsafe.org](http://www.iccsafe.org).

### Filter System

Prior to entering the gray water storage reservoir gray water must be filtered using an approved media, sand, or diatomaceous earth filter. An approved filter is one deemed acceptable to the code official or other authority having jurisdiction (Florida Building Code 2007). Filtration of the water before it enters the storage reservoir helps to reduce growth of bacteria and human pathogens. A full-open valve must also be installed downstream from the last plumbing fixture that is part of the gray water system and must be installed upstream of the filter. A full-open valve is a valve

such as a gate or ball valve. When open, a full-open valve allows water to pass through the entire cross-section of the pipe and does not create a constriction.

## Storage Reservoir

Gray water storage reservoirs must be constructed from durable, non-absorbent, and corrosive-resistant material. Storage reservoirs must be closed, gas-tight, and must have access openings that allow for inspection and cleaning. Storage reservoirs must be equipped with an overflow connection to a sanitary drainage system. The overflow pipe must be the same or larger diameter as the influent pipe. A drain must be installed at the lowest point of the reservoir and must be the same diameter of the overflow pipe. Both the overflow connection and drain must be indirectly connected to the sanitary drainage system. An indirect connection is one that discharges to the system through an air break into a receptor. Reservoirs must also be equipped with a vent sized according to the size of the influent pipe (Florida Building Code 2007).

Storage reservoirs must be sized to hold a minimum of twice the volume of water that is required to meet daily flushing needs and cannot store less than 50 gallons. Reservoirs must also be sized to limit the retention time of gray water within the reservoir to 72 hours or less (Florida Building Code 2007). Limiting the retention time of gray water helps to prevent growth of bacteria and human pathogens.

Reservoirs must be supplied with potable make-up water in the event of insufficient gray water supply. The potable water supply connection must be outfitted with a backflow prevention device and a full-open valve.

## Disinfection Unit

Gray water used for flushing of toilets and urinals must be disinfected prior to use by an approved method using one or more disinfectants such as chlorine, iodine, or ozone (Florida Building Code 2007).

While not explicitly listed in the building code, disinfection by ultraviolet light may also be considered an appropriate method. However, the definition of an approved method is one deemed acceptable to the code official or other authority having jurisdiction (Florida Building Code 2007).

## Coloring Dye Injection Unit

Before being supplied to the fixtures that will use the gray water, blue or green dye must be injected using a food-grade vegetable dye (Florida Building Code 2007).

## Potential Barriers to Gray Water Reuse

While reusing gray water has the potential to substantially reduce the use of fresh water there are several barriers which may impede the adoption of residential gray water reuse in Florida and elsewhere. These include:

- System cost
- Knowledge and experience of contractors and local officials
- Sufficient and consistent codes and guidelines
- Homeowner acceptance
- Limited permitted uses

Depending on the complexity of a gray water reuse system, the cost of retrofitting an existing home with separate plumbing, storage, and treatment may be perceived as too expensive, depending on the current regional cost of tap water and the availability of retrofitting incentives. The ease with which a legal, properly designed gray water system can be installed in a given location may be a major factor in homeowner or builder choice. If codes are vague or contradictory, or if permitting staff and contractors do not have knowledge and experience with gray water systems, the process of installing and permitting could be difficult. Possibly most important to the adoption of gray water reuse, is homeowner acceptance. The willingness of homeowners to incur the expense associated with maintenance and/or installation of gray water systems is central to widespread voluntary adoption.

Limitations on the permitted uses of gray water may reduce homeowner interest in gray water systems and can reduce the potential to conserve significant amounts of fresh water. For example, Florida no longer includes subsurface irrigation of non-edible portions of the landscape in its building codes (Florida Building Codes, 2009). However, when subsurface irrigation was included in the building codes (prior to March 1, 2009) treatment and disinfection requirements were less stringent than those for toilet and urinal flushing. Such systems were generally more simple, less expensive, and easier to maintain and were likely more desirable to interested homeowners. Certain restrictions on gray water reuse in some states, such as requiring subsurface irrigation systems as opposed to surface drip systems, can discourage the average homeowner from adopting such a system.

Gray water regulations are in place for a good reason, to protect public health. Some states take a more precautionary approach concerning gray water than others. Expanding the permitted uses of gray water may be perceived as a trade-off between protecting public health and conserving fresh water resources. The most effective framework to maximize reuse while maintaining effective public health protection is likely a topic of need of further research.

For many, the topic of using gray water may be a less-than palatable subject. It is likely that policy makers will be more receptive to expanding gray water reuse in the future as pressures increase on finite fresh water resources.

## References

Austin Green Building Program Sourcebook. Graywater. <http://greywater.sustainablesources.com/>

California Plumbing Code. (2007). Appendix G: Greywater systems. <http://www.iapmo.org/Pages/californiaplumbing-code.aspx>

Florida Building Code. (2007). Florida Building Code: Plumbing, Effective March 1, 2009. <http://www.florida-building.org/>

Florida Building Code. (2009). 2009 Supplement to the 2007 Florida Building Code, Effective March 1, 2009. <http://www.floridabuilding.org/>

Florida Department of Health. (2006). Chapter 64E-6, Florida Administrative Code, Standards for Onsite Sewage Treatment and Disposal Systems. <http://www.doh.state.fl.us/ENVIRONMENT/OSTDS/pdfiles/forms/64e6.pdf>

Gelt, J. (2007). Home use of graywater, rainwater conserves water—and may save money. University of Arizona Water Resources Research Center. <http://ag.arizona.edu/AZWATER/arroyo/071rain.html>

International Code Council (ICC). (2009). International Plumbing Code. International Code Council. Country Club Hills, IL.

Florida Statutes. (2008). Onsite sewage treatment and disposal systems; regulation. 381.0065 Florida Statutes. <http://www.leg.state.fl.us/STATUTES/>

Mayer, P.W., W.B. DeOreo, E.M. Opitz, J.C. Kiefer, W.Y. Davis, B. Dziegielewski, and J.O. Nelson. (1999). Residential End Uses of Water. American Water Works Research Foundation. 310pp. Denver, CO.

New Mexico Environment Department. (2009). Liquid Waste (Septic Tank) Program: Gray Water Information. <http://www.nmenv.state.nm.us/fod/LiquidWaste/graywater.html>

*Note: The International Code Council (ICC), a membership association dedicated to building safety and fire prevention, develops the codes used to construct residential and commercial buildings, including homes and schools. Most U.S. cities, counties and states that adopt codes choose the International Codes developed by the International Code Council.*

*ICC's Plumbing, Mechanical and Fuel Gas (PMG) is dedicated to the advancement of safe water delivery and sound sanitation principles that protect the public health and safety in concert with industry, government and the public by providing the highest quality codes, standards, products, and services for all concerned for the safety and performance of the built environment.*