

Specifications for Accident Prevention Signs and Tags -- OSHA Standard 1910.145¹

Carol J. Lehtola, Charles M. Brown and William J. Becker²

The Impact of Safety on Florida Agriculture

Florida agriculture, including forestry and seafood, made an annual economic impact of \$53 billion in 1998. More than 81,000 people work on the 40,000 farms in the state, and more than 50,000 are employed in other activities related to agriculture. The state's agricultural enterprises range from large citrus, vegetable and cattle operations to small family-operated farms.

From 1989 to 1998, there were approximately 240 deaths related to agriculture in Florida, according to data compiled by the Deep South Center for Agricultural Health and Safety. In addition, agriculture has one of the highest injury and death rates among U.S. industries.

Safety in Florida agriculture is challenging because:

- the state's agricultural enterprises are diverse,

- safety knowledge among workers varies,
- manual labor is used extensively,
- the climate creates year-round heat stress.

Therefore, it is vital to assist the public in learning about OSHA documents related to agriculture. More related information is available at the following Web sites:

Florida AgSafe:

<<http://agen.ufl.edu/~clehtola/agsaferef.htm>>

OSHA Regulations:

<<http://www.osha.gov/comp-links.html>>

Overview

This document, a condensation of Section 1910.145 of the Occupational Safety and Health Act (29 CFR), is not intended to be totally inclusive but rather to highlight the information and requirements in the complete OSHA standard that owners and managers of agricultural businesses should understand. Refer to the OSHA Web site given above

1. This document is ABE143, one of a series of the Agricultural and Biological Engineering Department, Florida Cooperative Extension Service, Institute of Food and Agricultural Sciences, University of Florida. Original publication date September 2000. Reviewed February 2008. Visit the EDIS Web Site at <http://edis.ifas.ufl.edu>.

2. Carol J. Lehtola, assistant professor and Extension Agricultural Safety Specialist; Charles M. Brown, coordinator information/publication services; William J. Becker, professor emeritus; Agricultural and Biological Engineering Department, Institute of Food and Agricultural Sciences, University of Florida, Gainesville.

for the complete standard and for court interpretations of the standard.

Contents of OSHA Standard 1910.145

- Section 1910.145(a) -- Scope
- Section 1910.145(b) -- Definitions
- Section 1910.145(c) -- Classification of Signs According to Use
- Section 1910.145(d) -- Sign Design
- Section 1910.145(e) -- Sign Wordings
- Section 1910.145(f) -- Accident Prevention Tags

NOTE: Some sections of OSHA standards are labeled "Reserved." This label implies either that information has been deleted from the previous version of the standard or that additions to the standard are anticipated. Because standards often reference other standards, it is important that paragraph numbers remain consistent.

Section 1910.145(a) -- Scope

1910.145(a)(1) -- These specifications apply to the design, application, and use of signs or symbols (as included in paragraphs (c) through (e) of this section) intended to indicate and, insofar as possible, to define specific hazards of a nature such that failure to designate them may lead to accidental injury to workers or the public, or both, or to property damage. These specifications are intended to cover all safety signs except those designed for streets, highways, railroads, and marine regulations. These specifications do not apply to plant bulletin boards or to safety posters.

1910.145(a)(2) -- All new signs and replacements of old signs shall be in accordance with these specifications.

Section 1910.145(b) -- Definitions

As used in this section, the word "**sign**" refers to a surface prepared for the warning of, or safety instructions of, industrial workers or members of the public who may be exposed to hazards. Excluded from this definition, however, are news releases, displays commonly known as safety posters, and bulletins used for employee education.

Section 1910.145(c) -- Classification of Signs According to Use

1910.145(c)(1) -- Danger signs

(i) -- There shall be no variation in the type of design of signs posted to warn of specific dangers and radiation hazards.

(ii) -- All employees shall be instructed that danger signs indicate immediate danger and that special precautions are necessary.

1910.145(c)(2) -- Caution signs

(i) -- Caution signs shall be used only to warn against potential hazards or to caution against unsafe practices.

(ii) -- All employees shall be instructed that caution signs indicate a possible hazard against which proper precaution should be taken.

1910.145(c)(3) -- Safety instruction signs

Safety instruction signs shall be used where there is a need for general instructions and suggestions relative to safety measures.

Section 1910.145(d) -- Sign Design

1910.145(d)(1) -- Design Features

All signs shall be furnished with rounded or blunt corners and shall be free from sharp edges, burrs, splinters, or other sharp projections. The ends or heads of bolts or other fastening devices shall be located in such a way that they do not constitute a hazard.

1910.145(d)(2) -- Danger Signs

The colors red, black, and white shall be those of opaque glossy samples as specified in Table 1 of Fundamental Specification of Safety Colors for CIE Standard Source "C", American National Standard Z53.1-1967, which is incorporated by reference as specified in Sec. 1910.6.

1910.145(d)(3) -- [Reserved]**1910.145(d)(4) -- Caution Signs**

Standard color of the background shall be yellow; and the panel, black with yellow letters. Any letters used against the yellow background shall be black. The colors shall be those of opaque glossy samples as specified in Table 1 of American National Standard Z53.1-1967.

1910.145(d)(5) -- [Reserved]**1910.145(d)(6) -- Safety Instruction Signs**

Standard color of the background shall be white; and the panel, green with white letters. Any letters used against the white background shall be black. The colors shall be those of opaque glossy samples as specified in Table 1 of American National Standard, Z53.1-1967.

1910.145(d)(7)-(9) -- [Reserved]**1910.145(d)(10) -- Slow-moving Vehicle Emblem**

This emblem (see Figure 1) consists of a fluorescent yellow-orange triangle with a dark red reflective border. The yellow-orange fluorescent triangle is a highly visible color for daylight exposure. The reflective border defines the shape of the fluorescent color in daylight and creates a hollow red triangle in the path of motor vehicle headlights at night. The emblem is intended as a unique identification for, and it shall be used only on, vehicles which by design move slowly (25 m.p.h. or less) on the public roads. The emblem is not a clearance marker for wide machinery nor is it intended to replace required lighting or marking of slow-moving vehicles. Neither the color film pattern and its dimensions nor the backing shall be altered to

permit use of advertising or other markings. The material, location, mounting, etc., of the emblem shall be in accordance with the American Society of Agricultural Engineers' "Slow-Moving Vehicle Identification Emblem," ASAE S276.5, 1998, which are incorporated by reference as specified in Sec. 1910.6.

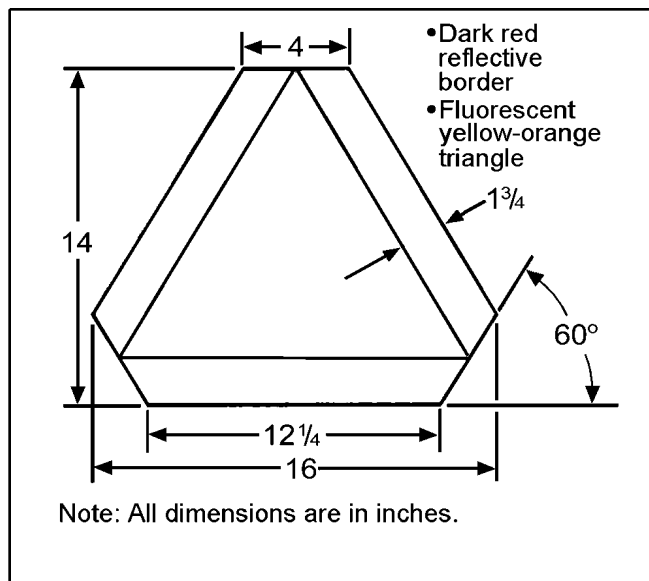

Figure 1. Specifications for Slow-Moving Vehicle (SMV) Symbol.

Section 1910.145(e) -- Sign Wordings**1910.145(e)(1) -- [Reserved]****1910.145(e)(2) -- Nature of Wording**

The wording of any sign should be easily read and concise. The sign should contain sufficient information to be easily understood. The wording should make a positive, rather than negative suggestion and should be accurate in fact.

1910.145(e)(3) -- [Reserved]**1910.145(e)(4) -- Biological Hazard Signs**

The biological hazard warning shall be used to signify the actual or potential presence of a biohazard and to identify equipment, containers, rooms, materials, experimental animals, or combinations thereof, which contain, or are contaminated with, viable hazardous agents. For the purpose of this subparagraph the term "biological hazard," or

"biohazard," shall include only those infectious agents presenting a risk or potential risk to the well-being of man.

Section 1910.145(f) -- Accident Prevention Tags

1910.145(f)(1) -- Scope and Application

(i) -- This paragraph (f) applies to all accident prevention tags used to identify hazardous conditions and provide a message to employees with respect to hazardous conditions as set forth in paragraph (f)(3) of this section, or to meet the specific tagging requirements of other OSHA standards.

(ii) -- This paragraph (f) does not apply to construction, maritime or agriculture.

1910.145(f)(2) -- Definitions

Biological hazard or BIOHAZARD -- Those infectious agents presenting a risk of death, injury or illness to employees.

Major message -- That portion of a tag's inscription that is more specific than the signal word and that indicates the specific hazardous condition or the instruction to be communicated to the employee. Examples include: "High Voltage," "Close Clearance," "Do Not Start," or "Do Not Use" or a corresponding pictograph used with a written text or alone.

Pictograph -- A pictorial representation used to identify a hazardous condition or to convey a safety instruction.

Signal word -- That portion of a tag's inscription that contains the word or words that are intended to capture the employee's immediate attention.

Tag -- A device usually made of card, paper, pasteboard, plastic or other material used to identify a hazardous condition.

1910.145(f)(3) -- Use. Tags shall be used as a means to prevent accidental injury or illness to employees who are exposed to hazardous or potentially hazardous conditions, equipment or

operations which are out of the ordinary, unexpected or not readily apparent. Tags shall be used until such time as the identified hazard is eliminated or the hazardous operation is completed. Tags need not be used where signs, guarding or other positive means of protection are being used.

1910.145(f)(4) -- General Tag Criteria. All required tags shall meet the following criteria:

(i) -- Tags shall contain a signal word and a major message.

(A) -- The signal word shall be either "Danger," "Caution," or "Biological Hazard," "BIOHAZARD," or the biological hazard symbol.

(B) -- The major message shall indicate the specific hazardous condition or the instruction to be communicated to the employee.

(ii) -- The signal word shall be readable at a minimum distance of five feet (1.52 m) or such greater distance as warranted by the hazard.

(iii) -- The tag's major message shall be presented in either pictographs, written text or both.

(iv) -- The signal word and the major message shall be understandable to all employees who may be exposed to the identified hazard.

(v) -- All employees shall be informed as to the meaning of the various tags used throughout the workplace and what special precautions are necessary.

(vi) -- Tags shall be affixed as close as safely possible to their respective hazards by a positive means such as string, wire, or adhesive that prevents their loss or unintentional removal.

1910.145(f)(5) -- Danger Tags. Danger tags shall be used in major hazard situations where an immediate hazard presents a threat of death or serious injury to employees. Danger tags shall be used only in these situations.

1910.145(f)(6) -- Caution Tags. Caution tags shall be used in minor hazard situations where a non-immediate or potential hazard or unsafe practice

presents a lesser threat of employee injury. Caution tags shall be used only in these situations.

1910.145(f)(7) -- Warning Tags. Warning tags may be used to represent a hazard level between "Caution" and "Danger," instead of the required "Caution" tag, provided that they have a signal word of "Warning," an appropriate major message, and otherwise meet the general tag criteria of paragraph (f)(4) of this section.

1910.145(f)(8) -- Biological Hazard Tags

(i) -- Biological hazard tags shall be used to identify the actual or potential presence of a biological hazard and to identify equipment, containers, rooms, experimental animals, or combinations thereof, that contain or are contaminated with hazardous biological agents.

(ii) -- The symbol design for biological hazard tags shall conform to the design shown in Figure 2.

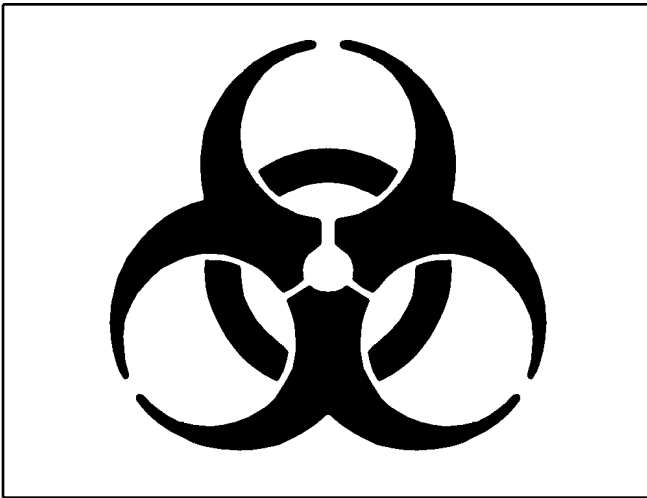

Figure 2. Biological Hazard Symbol.

1910.145(f)(9) -- Other tags. Other tags may be used in addition to those required by this paragraph (f), or in other situations where this paragraph (f) does not require tags, provided that they do not detract from the impact or visibility of the signal word and major message of any required tag.