

## Positive Displacement Pumps for Agricultural Applications<sup>1</sup>

---

Dorota Z. Haman, Forrest T. Izuno, Allen G. Smajstrla<sup>2</sup>

The primary function of a pump is to transfer energy from a power source to a fluid, and as a result, to create lift, flow or greater pressure on the fluid. A pump can impart three types of hydraulic energy to any fluid: lift, pressure, and velocity.

The classification of pumps used in this publication first defines the principle by which energy is added to the fluid, then identifies the means by which this principle is implemented, and finally, distinguishes among specific pump geometries commonly used. Under this classification system, all pumps may be divided into two major categories:

1. **dynamic pumps**, where continuously added energy increases the velocity of the fluid which is later converted to lift or pressure, and
2. **positive displacement pumps**, where periodically added energy directly increases pressure or lift.

This publication will only discuss positive displacement pumps. These pumps are normally used to produce high fluid pressures which are necessary

for numerous agricultural applications; among them, the injection of chemicals into a pressurized irrigation pipe system. Other applications include fluid transfers, sprayers, and chemical metering. Positive displacement pumps used for injection of chemicals in agricultural irrigation systems are discussed in more detail than other pumps. Dynamic pumps used for pumping water in agricultural applications are discussed in another publication.

Positive displacement pumps are self-priming, which is especially advantageous when handling hazardous chemicals. It is important to note that self-priming does not imply that air can be pumped against pressure or into a pressurized system to prime a pump. Rather, the discharge line should be vented to the atmosphere until all air is removed from the system during priming. This is important if the suction line is long, contains large quantities of air, or if the pump is discharging into a pressurized system upon starting. The pump is primed when all air is displaced by liquid in the suction line and there is a continuous liquid column in the discharge line.

---

1. This document is CIR826, one of a series of the Agricultural and Biological Engineering Department, Florida Cooperative Extension Service, Institute of Food and Agricultural Sciences, University of Florida. Original publication date June 1989. Reviewed June 2003. Visit the EDIS Web Site at <http://edis.ifas.ufl.edu>.

2. Dorota A. Haman, assistant professor, Department of Agricultural Engineering; Forrest T. Izuno, assistant professor, Everglades Research and Education Center, Belle Glade, FL 33430; Allen G. Smajstrla, professor, Department of Agricultural Engineering; Cooperative Extension Service, Institute of Food and Agricultural Sciences, University of Florida, Gainesville FL 32611.

Positive displacement pumps described in this publication can be subdivided into reciprocating and rotary pumps (Figure 1). This classification refers to whether a reciprocating or rotating mechanism is used to transfer energy to the fluid.

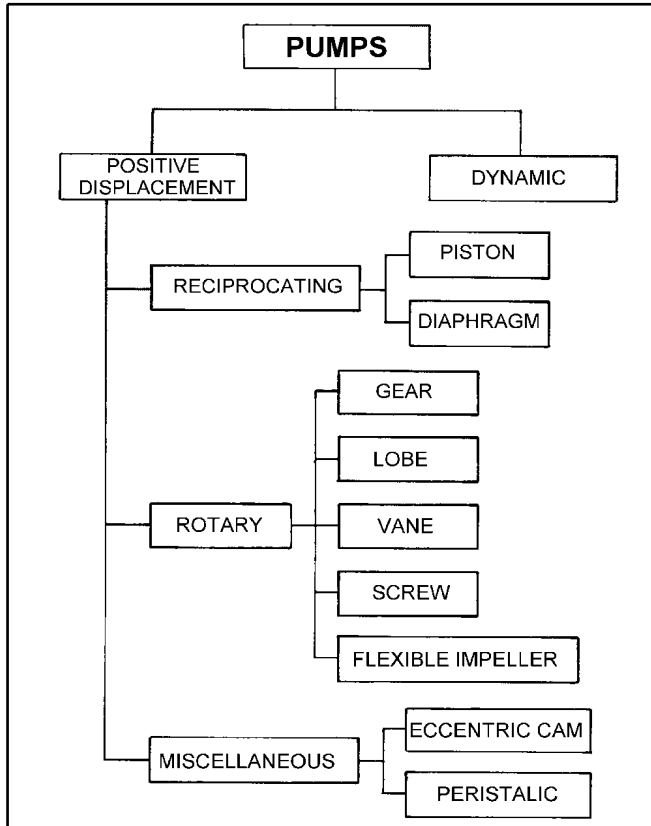

Fig. 1. Types of positive displacement pumps.

### RECIPROCATING PUMPS

A reciprocating pump is one in which a piston or a diaphragm displaces a given volume of liquid with each stroke. The change in internal volume of the pump creates the high pressure which forces liquid into the discharge pipe. Check valves on both the suction and the discharge sides of the pump allow the pumped liquid to flow in one direction only.

Reciprocating pumps are classified as piston or diaphragm pumps. This classification is based on the type of reciprocating element used to transfer energy to the fluid.

#### Piston Pumps

In piston pumps, a piston, which is attached to a mechanical linkage, transforms the rotary motion of a drive wheel into the reciprocating motion of the

piston. On an intake stroke (Figure 2a) the liquid enters the cylinder through the suction check valve. On a compression stroke (Figure 2b) it is forced into the discharge line through the discharge check valve. This action is similar to the action of a piston in the cylinder of an automobile engine.

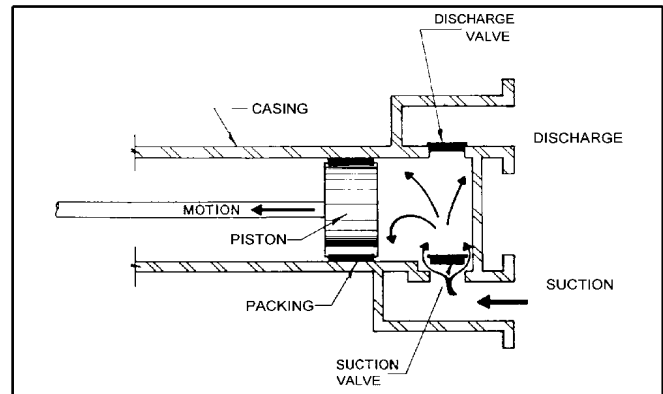

Fig. 2a. Piston pump - suction stroke.

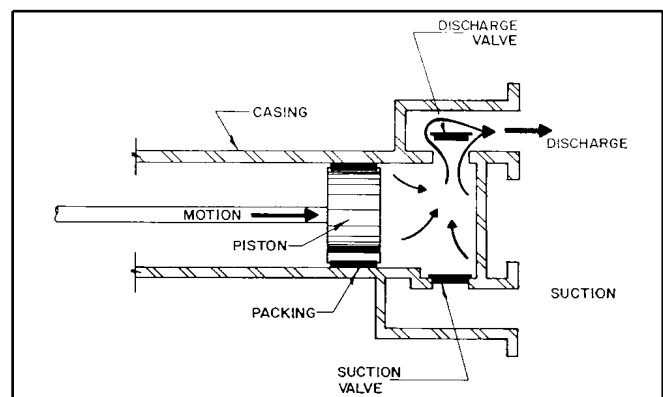
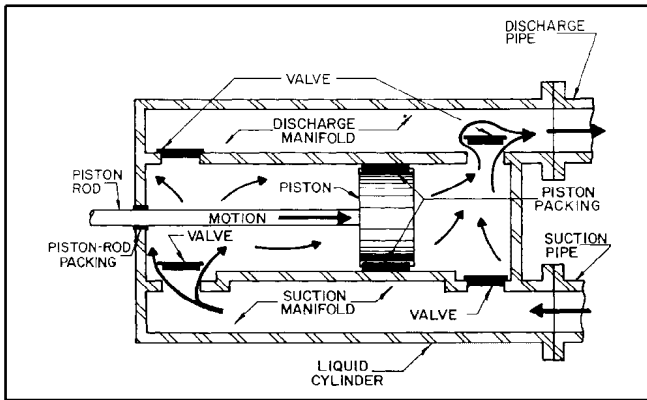

Fig. 2b. Piston pump - discharge stroke.

The flow rate of a simple piston pump is not constant since there is no flow on the intake stroke and the flow varies from zero to a maximum and back to zero on each compression stroke.

Pulsation of flow can be reduced by using a double action piston pump (Figure 2c) where the volume on both sides of the piston is used for pumping liquid. In this case, each suction stroke is a companion compression stroke for the opposite side of the pump and the liquid is pumped on both strokes.

To reduce the fluctuations even further, more than one cylinder can be employed in the same pump. In addition, each cylinder can be single or double acting. However, it should be noted that the pulsation of the flow is usually not a problem when chemicals are injected into an irrigation system, and pumps of



**Fig. 2c.** Double acting piston pump.

the type shown in Figure 2a and Figure 2b are commonly used for this purpose.

The flow rate of a piston pump can be varied by changing the reciprocating speed of the piston or the length of the piston stroke. Variable speed drive motors are also used sometimes to alter pumping rates, but this is a more expensive option. The upper limit for metering pumps of this kind is about 350 strokes per minute. Capacities of piston pumps vary from a few cubic inches per hour to 20 gpm. For chemical injection into irrigation systems, capacities in the range of 0.01 to 0.5 gpm are commonly used.

Piston pumps can create high pressures (up to 50,000 psi) and they deliver a constant flow rate independent of the discharge pressure. They can run dry without damage and do not require downstream check valves. Piston pumps are mechanically simple and can have an exceptionally long life if properly maintained. Maintenance is critical, however, because internal parts of the pump are in direct contact with the pumped liquid. This may create problems when corrosive chemicals are being pumped. In addition, piston pumps cannot be used for pumping abrasive liquids or chemicals which crystallize.

The cost of piston pumps ranges from several hundred to 2 or 3 thousand dollars. The more expensive models can be adjusted for calibration while operating, while the simpler models must be stopped for any adjustment. Piston pumps are bulky, heavy, and can have a significantly pulsating discharge.

## Diaphragm Pumps

Diaphragm pumps are the most common positive displacement pumps used in agricultural applications. The operation of a diaphragm pump is similar to that of a piston pump. The pulsating motion is transmitted to the diaphragm through a fluid or a mechanical drive, and then through the diaphragm to the pumped liquid. A schematic of this type of pump is presented in Figure 3a and Figure 3b.

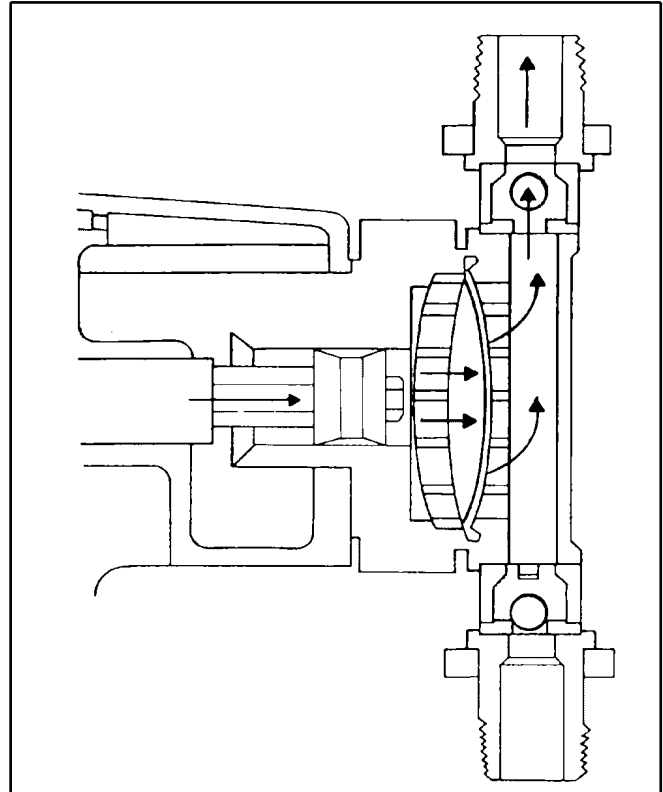

**Fig. 3a.** Diaphragm pump - suction stroke.

A major advantage of diaphragm pumps is that the pumped liquid does not come into contact with most of the working parts of the pump. The only moving parts which are in contact with the pumped liquid are the diaphragm and the suction and discharge check valves. Hence, diaphragm pumps are suitable for pumping corrosive liquids which is often the case with chemical injection into an irrigation system.

For diaphragm pumps, the pumping characteristics depend on the method by which the driving force is transmitted to the diaphragm. Less expensive (\$200 - \$500) diaphragm pumps are mechanically driven. They use an unsupported

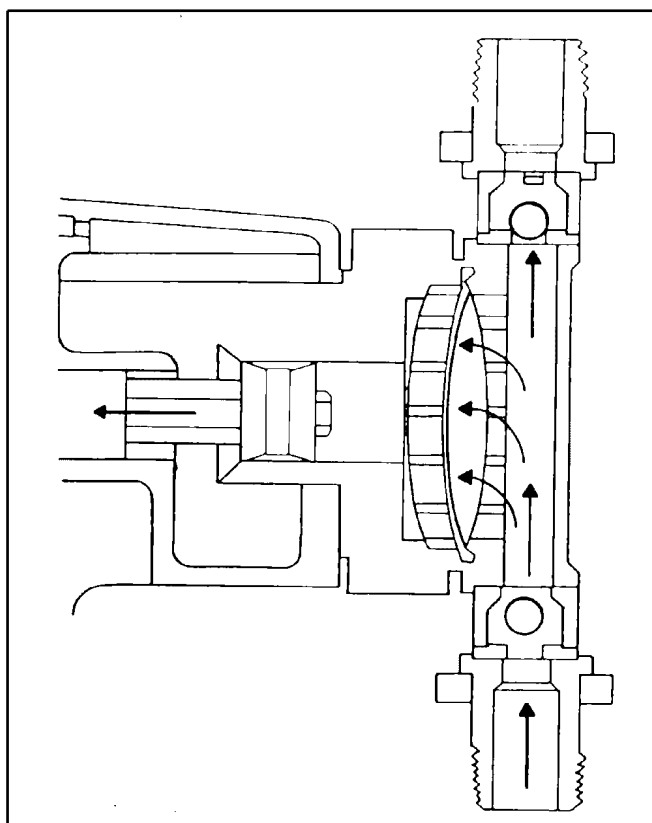

**Fig. 3b.** Diaphragm pump - discharge stroke.

diaphragm which is moved in the discharge direction by a cam or by a piston. These mechanically driven diaphragm pumps have pressure limitations of 125 to 150 psi and capacity limits of 12 to 15 gpm.

The pumping rate for mechanically driven diaphragm pumps vary with the pressure that the pumps are operating against. Thus, field calibration while pumping against a pressurized system is required for accurate calibration. However, diaphragm pumps are made to be adjustable while operating, which makes the process of calibration easier.

Since most irrigation systems operate at a constant, predetermined pressure, mechanical diaphragm pumps are often used for chemical injection into an irrigation system. Once calibrated for the operating pressure, the pump does not have to be frequently adjusted.

Liquid-driven diaphragm pumps provide all of the advantages of both piston pumps and mechanically driven diaphragm pumps. They can create the same high pressures as piston pumps. For liquid-driven diaphragm pumps, the pumping rate is

also independent of the discharge pressure (as in piston pumps) since for all practical purposes liquid is incompressible. The discharge capacity of these pumps is up to 20 gpm, but rates of 0.01 to 0.5 gpm are most common for chemical injection applications.

Liquid-driven diaphragm pumps are usually significantly more expensive (\$1,500 - \$3,000) than mechanically driven diaphragm pumps and, for some applications, this additional expense cannot be justified. Liquid-driven diaphragm pumps are often used when high precision is required such as for injection of pesticides into irrigation systems.

Diaphragm pumps can be run dry for extended periods of time without damage. However, operation against a closed discharge must be avoided since high pressure may build up on a discharge side. Shutoff valves, responding to high pressure on the discharge side, should be installed on the suction side of the pump.

Most diaphragm pumps can be adjusted for calibration when running. If the length of stroke can be adjusted using a mechanical linkage, they do not require variable speed drives to alter pump discharge.

## ROTARY PUMPS

Rotary pumps transfer liquid from suction to discharge through the action of rotating gears, lobes, vanes, screws, or similar mechanisms. These rotating elements operate inside a rigid casing. Rotary pumps do not require check valves for proper operation. However, these pumps are often equipped with check valves to assist with priming and to avoid backward flow when the pump is stopped.

Rotary pumps can be classified into the following groups (Figure 1): gear, lobe, vane, screw, flexible impeller. This classification is based on the type of rotating element used to transfer energy to the fluid.

### Gear Pumps

A gear pump can be classified as internal (Figure 4) or external (Figure 5) depending on the position of the gears. In the internal gear pump (Figure 4) the inside gear is attached to the pump drive shaft and the outside gear, which is a part of the pump casing, is an

idler gear. In the external gear pump there are two meshing gears of equal size (Figure 5) located in the pump case. One of the gears is attached to the pump shaft and the other is an idler gear.

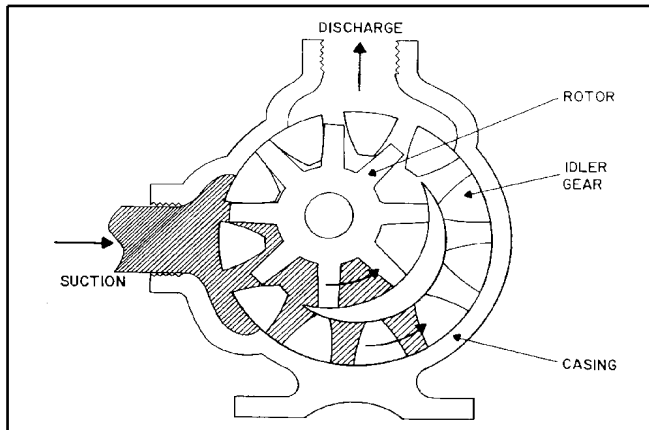

Fig. 4. Internal gear pump.

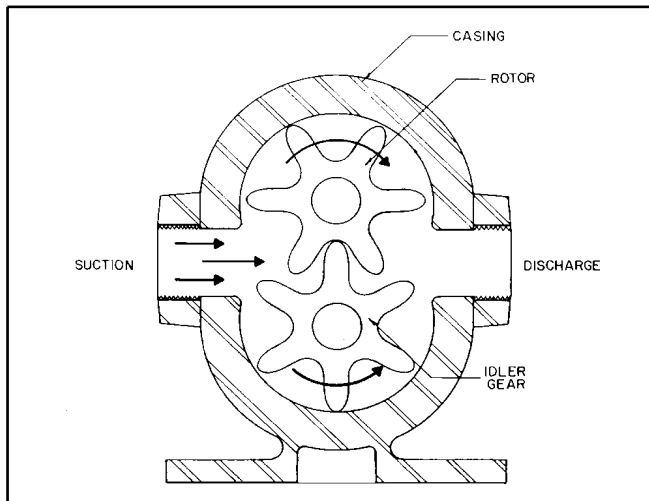

Fig. 5. External gear pump.

The operation of a gear pump is based on the partial vacuum which is created by the unmeshing of the rotating gears. This vacuum causes liquid to flow into the pump. Then, the liquid is carried between the gears and the casing to the discharge side of the pump. The meshing of the rotating gears on the discharge side prohibits backward flow and generates an increase in pressure which forces liquid into the outlet line.

Both internal and external gear pumps can theoretically be run in either direction, but in most cases they are equipped with pressure relief valves which prevent buildup of pressure above safe levels. The recommended direction of flow is clearly marked

on the outside of the pumps. Check valves are sometimes also used to insure proper direction of flow.

Gear pumps produce a constant discharge for a set speed of rotation, thus the pulsation of flow is negligible. They depend on the pumped liquid for lubrication and they can be damaged when they run dry. Gear pumps can easily be damaged when operating against a closed discharge and, therefore, a pressure relief valve is a necessary part of the pump installation. A bypass valve, which returns part of the liquid from the discharge to the suction side of the pump when the pressure is too high, is used by some manufacturers to prevent pump damage.

The alignment of internal parts in a gear pump is very critical because close clearances between moving parts are essential. As a result, abrasive fluids quickly damage these pumps. Gear pumps should be used for chemical injection of nonabrasive liquids only. They are also used in some hydraulic servo systems, sprayers, and as pumps for machine-tool services.

## Lobe Pumps

Lobe pumps operate like external gear pumps, but the gears are replaced by impellers which have two or three lobes. Figure 6 illustrates a three-lobe pump with two impellers. The number of lobes will determine the amount of pulsation from the pump output. The greater the number of lobes, the more constant is the discharge from the pump.

The lobed impellers are easier to replace and tend to wear less with abrasives than the gears in the gear pump. The alignment is also less critical in the lobe pump than in the gear pump.

Lobe pumps are self-priming and can pump liquid which contains vapor or air. For these reasons lobe pumps are frequently used in vacuum pumps and compressors.

## Vane Pumps

In vane pumps, fluid is pumped using a rotor mounted off-center in the pump casing. Rectangular vanes are placed at regular intervals around the rotor, and the vanes are free to move in a slot (Figure 7). As

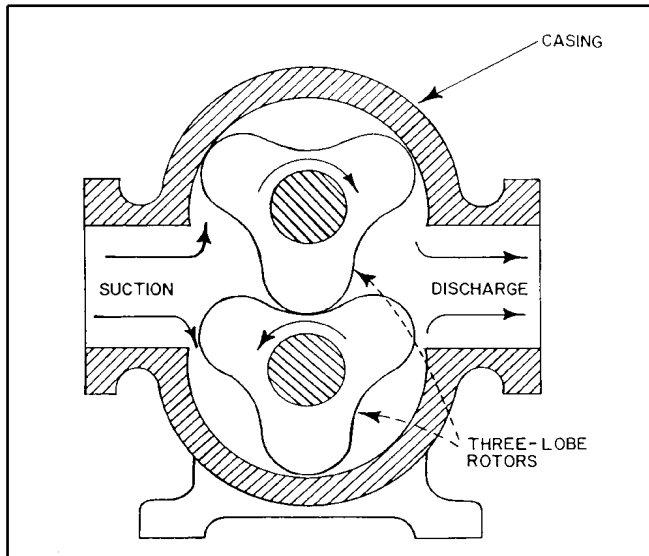

**Fig. 6.** Lobe pump with two impellers.

the rotor spins, the vanes are moved toward the casing by centrifugal force, and they form chambers in which the fluid is moved along the casing. Liquid enters the pump due to the vacuum which is created by the eccentricity (off-center location) of the rotor when in operation. The same eccentricity creates the pressure at the outlet.

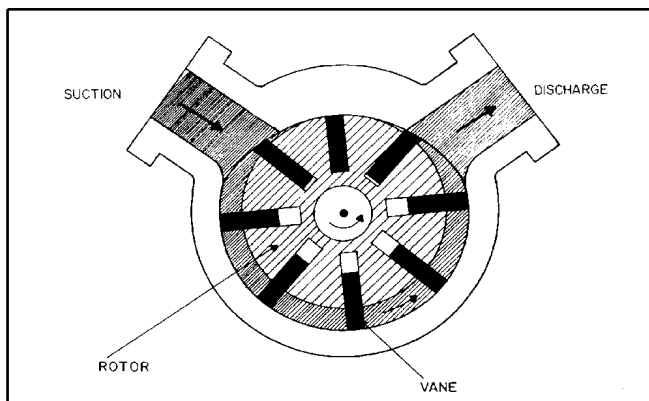

**Fig. 7.** Vane pump.

Vane pumps produce a constant flow rate for a given rotor speed. The pulsation is negligible and the original capacity is not affected until the vanes are significantly worn. These pumps can be operated in either direction. Like most of the positive displacement pumps, vane pumps cannot operate against a closed discharge without damage to the pump. Because of this, pressure relief valves are often installed on the discharge side of the pump and check valves are used to establish direction of flow.

Vane pumps are frequently used for lubrication of machine-tools, and in electro-hydraulic control systems. They are also used in some spraying equipment.

### Screw Pumps

Screw pumps consist of helical screws which revolve in a fixed casing (Figure 8). As the screw rotates in the casing, a cavity created between the screw and the casing progresses towards the discharge side of the pump. This movement creates a partial vacuum which draws liquid into the pump. The shape of the casing at the discharge end is such that the cavity becomes closed. This generates pressure, pushing the liquid into the discharge line. Some screw pumps use double screws which guide the liquid to the same discharge point.

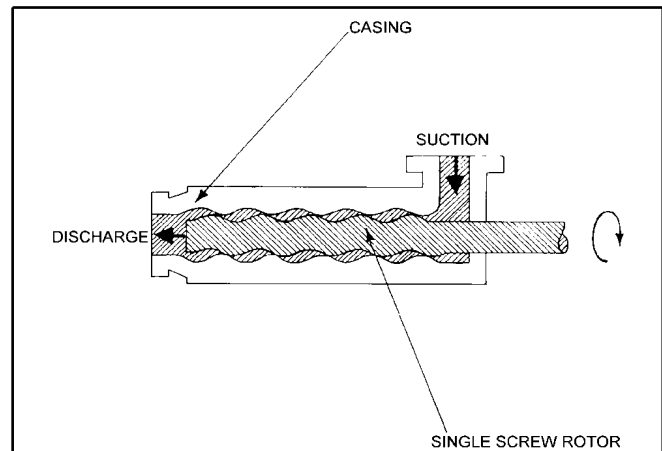

**Fig. 8.** Single screw pump.

Screw pumps produce a constant discharge with negligible pulsation. They have an exceptionally long life expectancy. They are built in a very wide range of sizes and capacities with pressure ranges from 50 to 5000 psi. A pressure relief valve is required at the installation since screw pumps cannot be operated against a closed discharge. Screw pumps can operate in one direction only.

Significant disadvantages of screw pumps are that they are bulky and heavy. Application of screw pumps in agriculture is limited to food processing and hydraulic systems for machine tools.

### Flexible Impeller Pumps

Flexible impeller pumps consist of flexible-bladed impellers which are placed eccentrically in casings (Figure 9). The impeller blades unfold as they pass the suction port, creating a partial vacuum which causes liquid to flow into the pump. As the rotor moves, the blades bend due to the eccentric placement of the rotor, resulting in a squeezing action on the liquid and increased pressure. The discharge of a flexible impeller pump is thus uniform with negligible pulsation.

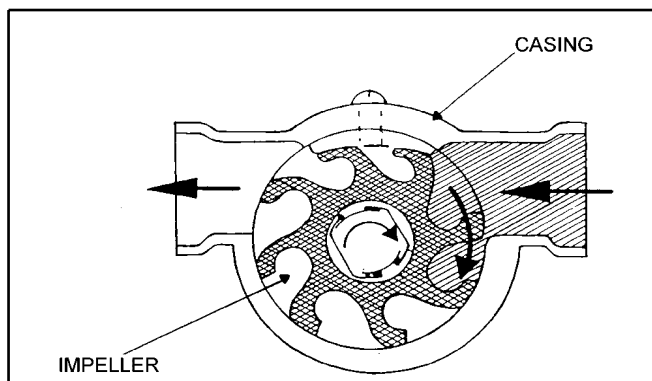

Fig. 9. Flexible impeller pump.

Flexible impeller pumps are typically not equipped with pressure relief or check valves, because they can operate against a closed discharge for a short time without damage and the contact between the impeller and casing prevents backwards flow. These pumps cannot pump against high pressure and are usually used in applications where the pressure does not exceed 30 psi. Because of pressure limitations, the flexible impeller pumps are not usually selected for the injection of chemicals into irrigation systems. They are commonly used as fluid transfer and low pressure metering pumps.

### MISCELLANEOUS PUMPS

Eccentric cam pumps and peristaltic pumps are discussed here. They differ from the previously discussed rotary pumps by the fact that the liquid being pumped is not in direct contact with a rotating element.

#### Eccentric Cam Pumps

Eccentric cam pumps are also called rotating piston or plunger pumps (Figure 10). These pumps

have some of the characteristics of both rotary and reciprocating pumps. The primary component of these pumps is the eccentric cam which rotates within a circular housing inside a cylindrical plunger which is in direct contact with the pumped liquid. Cam rotation causes the cylindrical plunger to change position relative to the fixed casing. The cavity created between the plunger and the housing transmits the fluid towards the pump discharge. During the cam cycle the volume available for liquid inside the pump progressively decreases, resulting in increased pressure at the discharge side of the pump.

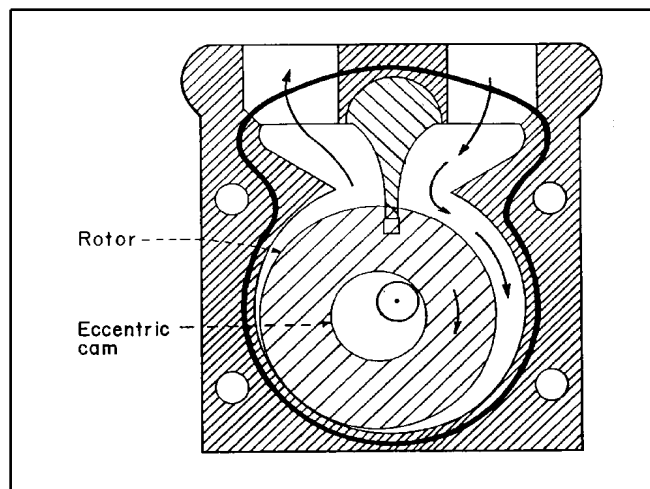

Fig. 10. Eccentric cam pump.

Eccentric cam pumps are self-priming, do not require check valves and can pump in either direction. These pumps have their primary moving parts separated from the pumped liquid, and therefore can be used for pumping corrosive substances.

There are other variations of cam pumps, such as: diaphragm cam pumps, flexible liner cam pumps, and variable volume eccentric cam pumps (also called sliding shoe pumps) which are sometimes used for agricultural applications. More information on these pumps can be found in Holland and Chapman (1966).

#### Peristaltic Pumps

Figure 11 shows a typical peristaltic pump. A flexible tube passes through the fixed casing of the pump. A rotor with rollers attached to it moves and presses against the flexible tube. This squeezing action produces an even flow of liquid. For proper action it is important that the tubing is flexible

enough to allow the rollers to squeeze it until it is completely closed. Special tubing, often tygon tubing, is used with peristaltic pumps. Because rollers continuously pass over and compress it, the tubing life expectancy is limited. This life varies with the type of tubing, but averages about 200 hours.

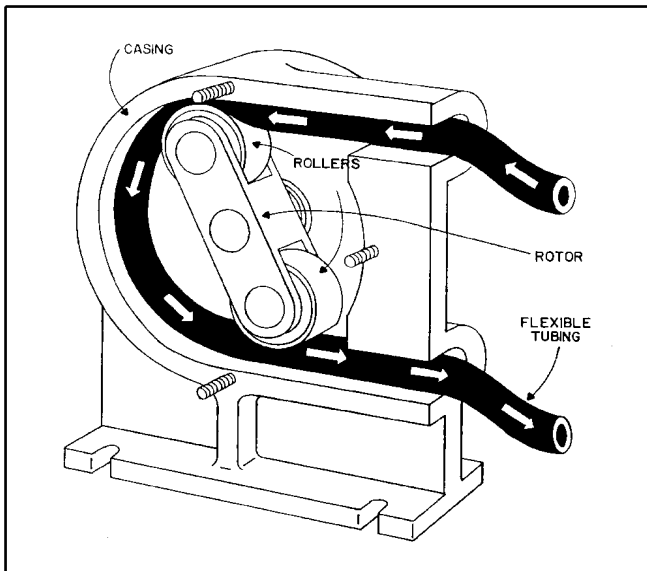

Fig. 11. Peristaltic pump.

Peristaltic pumps are self-priming. They do not require check valves. The pumped fluid is completely isolated from the moving parts, which permits pumping of corrosive substances. These pumps can be run dry for extended periods of time without damage to the pump.

Peristaltic pumps are used mostly in chemical laboratories, but they can be used for injection of chemicals into small irrigation systems. Their capacity is limited and most of them produce relatively low pressure (30-40 psi). However, special models are manufactured which can produce up to 100 psi.

## OPERATING PROBLEMS

Common problems that occur during operation of positive displacement pumps are presented in Table 1. Six common problems and possible reasons for each one are addressed in this table:

1. the pump does not deliver any liquid,
2. the pump delivers less liquid than its rated capacity,

3. the prime is lost during operation of the pump,
4. the pump is noisy,
5. the pump wears more rapidly than should be expected, and
6. the pump takes too much power.

## SUMMARY

Different types of positive displacement pumps are discussed in this publication. Positive displacement pumps are classified as reciprocating and rotary types depending on the mechanism used to transfer energy to the fluid. Reciprocating pumps, including both diaphragm and piston types, are commonly used for chemical injection into agricultural irrigation systems. Rotary pumps include gear, lobe, vane, screw, flexible impeller, eccentric cam and peristaltic pumps. Basic principles of operation, typical applications, advantages and disadvantages of each type are presented.

## REFERENCES

- Holland F. A., F. S. Chapman. 1966. *Pumping of Liquids*. Reinhold Publishing Corporation, New York.
- Hydraulic Handbook*. 1979. Colt Industries, Fairbanks Morse Pump Division, Kansas City, Kansas.
- Karassik I. J., W. C. Krutzsch, W. H. Fraser, J. P. Messina. 1976. *Pump Handbook*. McGraw-Hill Book Company, New York.

Table 1.

Table 1. Problems with operation of positive displacement pumps.							
No liquid delivered	Pump delivers less than rated capacity	Loss of prime while pump is operating	Pump is noisy	Rapid pump wear	Pump takes too much power		
1. Pump not primed	1. Air leak in suction line or pump seal	1. Liquid level falls below the suction line intake	1. Cavitation	1. Pipe strain on pump casing	1. Speed too high		
2. Insufficient NPSHa	2. Insufficient NPSHa	2. Air lead develops in pump or seal	2. Misalignment	2. Grit or abrasive material in liquid	2. Shaft packing too tight		
3. Suction line strainer clogged	3. Suction line strainer clogged or insufficient area	3. Air lead develops in suction line	3. Foreign material inside pump	3. Pump running dry	3. Liquid more viscous than specified		
4. End of suction line in water	4. Wear on pump leads to increased clearances and slip	4. Liquid vaporizes in suction line	4. Bent rotor shaft (for rotary pumps)	4. Corrosion	4. Misalignment		
5. Relief valve set lower than minimum required discharge pressure	5. Relief valve wrongly set		5. Relief valve chattering		5. Obstruction in discharge line raises operating pressure		
6. Relief valve jammed open	6. Relief valve jammed open				6. Discharge line too small		
7. Pump rotates in wrong direction	7. Speed too low				7. Discharge valve partially closed		
8. Suction or discharge valves closed	8. Suction or discharge valves partially closed						

Table 1.

Table 1. Problems with operation of positive displacement pumps.					
No liquid delivered	Pump delivers less than rated capacity	Loss of prime while pump is operating	Pump is noisy	Rapid pump wear	Pump takes too much power
9. Bypass valve open	9. Bypass valve partially open				
	10. Liquid viscosity differs from that specified in pump selection				